

BRECOclassic® HTD8 CLA

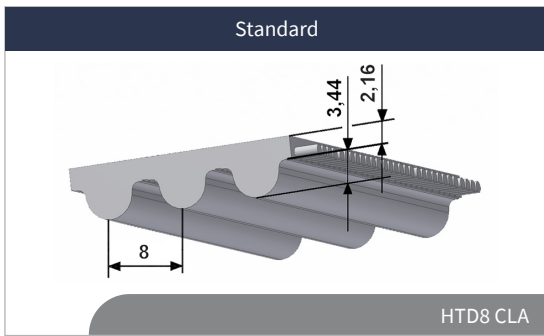

Belt widths b [mm] (In-between belt widths on request)			
25	50	75	100

Available length and versions	HTD8 CLA	Comment
Standard lengths	rolls of 50 or 100 m	-
Cut to lengths / lengths > 100 m	on request	-
In-between belt widths / other widths	not available	-
minimum length endless joined (b=100 mm)	880 mm	-
minimum length endless joined (b>100 mm)	-	-
Standard material	TPUCLA	-
Steel tension member	Standard	-
E tension member	not available	-
Stainless steel cord	not available	-
PAZ	available	-
PAR	not available	-
PAZ-PAR	available	-
DL / DL-PAZ	not available	-
DR / DR-PAZ	not available	-
T / T-PAZ	not available	-

Tooth shear strength (specific belt tooth load bearing)

R.p.m. n [min-1]	F _{tspez} [N/cm]	R.p.m. n [min-1]	F _{tspez} [N/cm]	R.p.m. n [min-1]	F _{tspez} [N/cm]	R.p.m. n [min-1]	F _{tspez} [N/cm]
0	87.5	800	62.148	2,000	48.006	5,000	32.079
20	86.216	900	60.475	2,200	46.413	5,500	30.362
40	85.013	1,000	58.937	2,400	44.943	6,000	28.787
60	83.881	1,100	57.514	2,600	43.578	6,500	27.333
80	82.814	1,200	56.19	2,800	42.305	7,000	25.982
100	81.803	1,300	54.953	3,000	41.112	7,500	24.721
200	77.426	1,400	53.791	3,200	39.989	8,000	23.538
300	73.87	1,500	52.696	3,400	38.929	8,500	22.425
400	70.877	1,600	51.661	3,600	37.925	9,000	21.374
500	68.291	1,700	50.679	3,800	36.972	9,500	20.377
600	66.016	1,800	49.746	4,000	36.064	10,000	19.43
700	63.984	1,900	48.856	4,500	33.967		

HTD8 CLA

HTD8 CLA		Admissible tensile force of the belt F _{adm} / belt weight				
belt width		b [mm]	25	50	75	100
M	E / Steel tension member	F _{Tadm} [N]	4,250	8,500	12,750	17,000
	Specific elasticity (E- / Steel tension member)	C _{spez} [N]	1.06·10 ⁶	2.12·10 ⁶	3.18·10 ⁶	4.25·10 ⁶
	Stainless steel cord	F _{Tadm} [N]	-	-	-	-
	Specific elasticity (stainless steel tens. m.)	C _{spez} [N]	-	-	-	-
V	E / Steel tension member	F _{Tadm} [N]	2,125	4,250	6,375	8,500
	Stainless steel cord	T _{adm} [N]	-	-	-	-
Belt weight (Standard)		[kg/m]	0.16	0.32	0.48	0.64
Belt weight (DL)		[kg/m]	-	-	-	-
Belt weight (DR)		[kg/m]	-	-	-	-
Belt weight (T)		[kg/m]	-	-	-	-

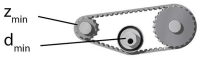
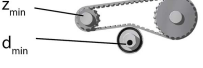
HTD8 CLA		Flexibility (Minimum number of teeth / minimum diameter)											
		Steel tension member				E / Steel tension member				Stainless steel cord			
		Standard	DL	DR	T	Standard	DL	DR	T	Standard	DL	DR	T
	Minimum number of teeth without contraflexure (z_{min})	20	-	-	-	-	-	-	-	-	-	-	-
	Minimum diameter of tensioning roller without contraflexure (d_{min} [mm])	50	-	-	-	-	-	-	-	-	-	-	-
	Minimum number of teeth with contraflexure (z_{min})	32	-	-	-	-	-	-	-	-	-	-	
	Minimum diameter of tensioning roller with contraflexure (d_{min} [mm])	120	-	-	-	-	-	-	-	-	-	-	